

## WEB CLEANER

### Web cleaner head BR31



Based on 30 years experience, we are now launching further 4th generation of web cleaner heads for moving webs, the KELVA BR31. Using the experiences from more than 2,500 installations around the world, we have developed our concept even further. The BR31 is quieter, more efficient, and more flexible to install and adjusted to suit your requirements.

KELVA web cleaners clean both sides of a moving web simultaneously. The web cleaner head breaks up the boundary layer along the web and the blown air creates turbulence and vibration that shakes loose the dust. The swirling dust is then vacuumed out through the web cleaner head into a filter where it is collected. The web cleaner is also equipped with an antistatic device, which eliminates static charges in the material.



## Product description

Product name	KELVA web cleaner head BR31
Application	Cleaning of moving webs
Max profile length	2200 mm with connections at one end 5000 mm with connections at both ends
Profile length	Web width + minimum 20 mm
Opening options	Pneumatic, opening 40mm or 100mm
Antistatic system options	Passive carbon fibre discharger Active discharging
Additional options	Sound muffler hoods for extremely quiet environments

## Dimensions

All measurements in mm

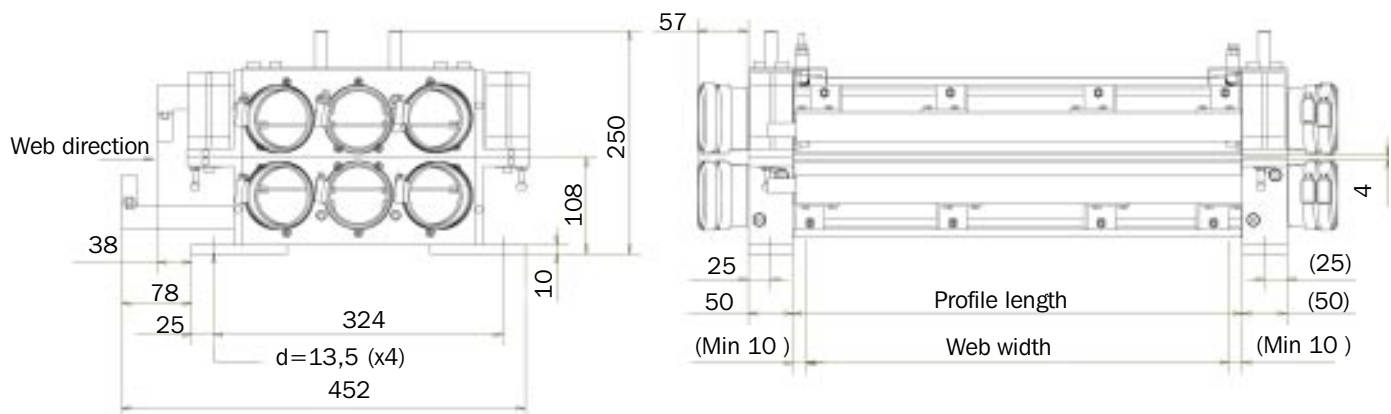

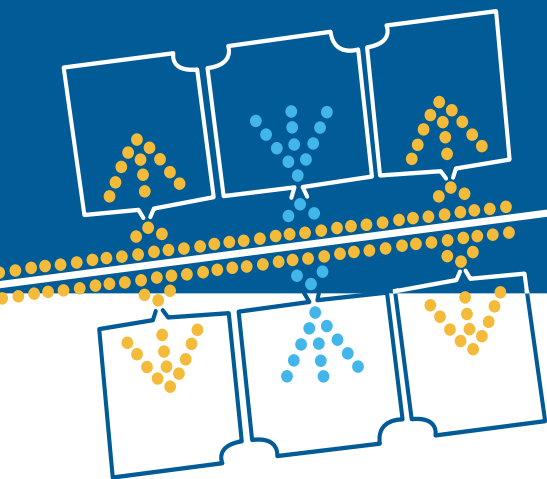

## WEB CLEANER

### Filter- and fan unit K-55

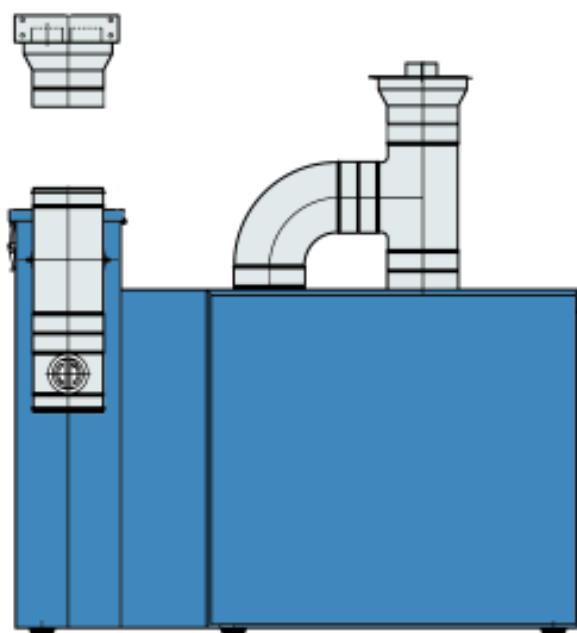

In order to provide the pressure and vacuum air necessary and to separate the dust removed, the web cleaner head is connected to a filter fan unit. The web cleaner K-55 is used for converting industry having web widths up to 1650mm. Two K-55's, connected one to each side of the web cleaner head, can be used for web widths up to 3500mm.



## Product description

Product name	KELVA filter- and fan unit K-55
Application	For connection to web cleaner heads BR31 and BR51
Electrical data	220-240V/380-420V, 50Hz, 3 phase, 5.5kW, 10.9A 255-280V/440-480V, 60Hz, 3 phase, 6.3kW, 10.6A
Filter options	Textile, polyester or paper Microfilter
Control box options	With filter alarms, type C-230, Size: 430x300x188mm Star-delta starting and filter alarms, type CD-230, Size: 430x300x188mm
Additional options	Motorized valves for pressure and vacuum air control

## Dimensions

All dimensions in mm

